

F-Series

F-Series

CIRCUIT BREAKER

The F-Series hydraulic-magnetic high amperage circuit breakers are designed to handle high current applications in extremely hot and/or cold locations. Due to its time-proven hydraulic-magnetic design, the F-Series load sensing mechanism is insensitive to changes in ambient or enclosure temperature, providing a consistent trip point over temperatures ranging from -40°C to +85°C. Additionally, the F-Series circuit breakers come with a choice of overload time delays, making them ideal for critical applications having inductive loads.

Further, the F-Series breakers are available up to 700A and an optional 25 millivolt metering shunt construction provides a safe method for monitoring current flowing through the breaker by simply connecting a meter with light gauge wire to the appropriate terminals located on the shunt housing at the rear of the breaker. Applications can be customized by measuring and displaying percentage of current, watts or safe/danger zones.

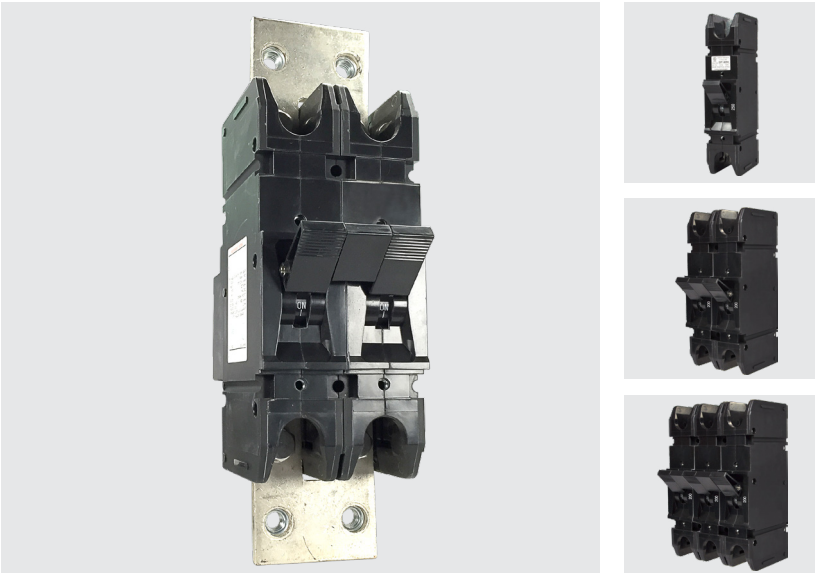

Product Highlights:

- AC ratings to UL 489
- DC voltage ratings up to 700A with metering shunt section
- Consistent trip point over temperatures ranging from -40°C to +85°C
- Optional 25 millivolt metering shunt construction

Typical Applications:

- Ideal for applications under extreme temperatures
- Higher Amperage Applications
- Battery Disconnect Systems
- Solar Power Systems
- Military



Carling Technologies®

Innovative Designs. Powerful Solutions.

Techna

www.techna.co.uk

Electrical

Maximum Voltage	125VDC, 277VAC
Current Ratings	Standard current coils: 100, 125, 150, 175, 225, 250 amps. 300, 350, 400, 500, 600, 700 amps available as parallel pole construction.
Auxiliary Switch Rating	SPDT; 10.1 Amps @ 250VAC, 1.0 Amps @ 65VDC, 0.5 Amps @ 80VDC 0.1 Amps @ 125VAC (with gold contacts).
Insulation Resistance	Minimum: 100 Megohms at 500 VDC
Dielectric Strength	1960 VAC, 50/60 Hz for one minute between all electrically isolated terminals, except 2500 VAC for one minute between alarm/aux. switch and main terminals with contacts in open and closed position. F-Series circuit breakers comply with the 8mm spacing & 3750VAC 50/60 Hz dielectric requirements from hazardous voltage to operator accessible surfaces, between adjacent poles and from main circuits to auxiliary circuits per Publications EN 60950 and VDE 0805.
Resistance, Impedance	Values from Line to Load Terminal - based on Series Trip Circuit Breaker.

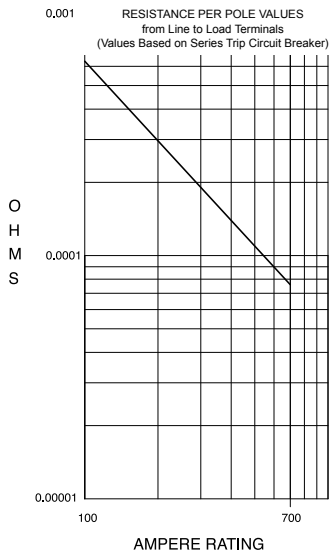

CURRENT (AMPS)	TOLERANCE (%)
100 - 700	50

Mechanical

Endurance	4000 ON-OFF operations with rated Current & Voltage & 4000 operations with no load (8000 operations total) @ 5 per minute. Parallel Pole construction: 1000 operations with rated Current and Voltage @ 5 per minute.
Trip Free	All F-Series Circuit Breakers will trip on overload, even when the actuator is forcibly held in the ON position.
Trip Indication	The operating actuator moves positively to the OFF position when an overload causes the circuit breaker to trip.

Physical

Number of Poles	1 - 3 Poles Note: Ratings over 250 Amps only available with parallel pole.
Internal Circuit Config.	Series (with or without auxiliary switch), Switch Only (with or without auxiliary switch).
Available Accessories	Factory installed: DC Current Metering Shunt (25 mV @Ir)
Weight	Varies depending on construction. Consult factory.
Standard Colors	Housing - Black; Actuator- Black or White with contrasting ON-OFF legend.

Environmental

Designed and tested in accordance with requirements of specification MIL-PRF-55629 & MIL-STD-202 as follows:

Shock	Withstands 100 Gs, 6ms, sawtooth while carrying rated current per Method 213, Test Condition "I". Instantaneous and ultra-short curves tested @ 90% of rated current.
Vibration	Withstands 0.060" excursion from 10-55 Hz, and 10 Gs 55-500 Hz, at rated current per Method 204C, Test Condition A. Instantaneous and ultrashort curves tested at 90% of rated current.
Moisture Resistance	Method 106D; ten 24-hour cycles @ + 25°C to +65°C, 80-98% RH.56 days @ +85°C, 85% RH.
Salt Spray	Method 101, Condition A (90-95% RH @ 5% NaCl Solution, 96 hrs).
Thermal Shock	Method 107D, Condition A (Five cycles @ -55°C to +25°C to +85°C to +25°C).
Operating Temperature	-40° C to +85° C

*Manufacturer reserves the right to change product specification without prior notice.

Electrical Tables

Table A: Lists UL Listed (489) and CSA Certified (C22.2 N0. 5.1-M) configurations and performance capabilities as a Molded Case Circuit Breaker

F SERIES TABLE A : UL489 LISTED BRANCH CIRCUIT BREAKERS						
CIRCUIT CONFIGURATION	VOLTAGE			CURRENT RATING	INTERRUPTING CAPACITY (AMPS)	
	MAX RATING	FREQUENCY	PHASE		FULL LOAD AMPS	UL / CSA
				1 - 3 POLES		1 or 2 POLES
SERIES	125	DC	---	50 - 250	50,000	25,000
	120 / 240 ¹	50 / 60	1	100 - 250	10,000	---
	277	50 / 60	1	100 - 250	10,000	---
	208Y / 120	50 / 60	3	100 - 250	10,000	---

Notes:

1 120/240V rating available in 2 or 3 poles. In a 3 pole construction the center pole is Neutral.

2 TUV constructions are not available with AC ratings and 150-250 amp ratings only.

Table B: Lists UL Listed configurations and performance capabilities as Circuit Breakers for use in Communications Equipment (Guide DITT, File E189195), under UL489A

F-SERIES TABLE B : UL489 LISTED BRANCH CIRCUIT BREAKERS				
CIRCUIT CONFIGURATION	VOLTAGE		CURRENT RATING	INTERRUPTING CAPACITY (AMPS)
	MAX. RATING	FREQUENCY		
SERIES	125	DC	251 - 700	50,000

Agency Certifications

UL Listed

UL 489



Circuit Breakers , Molded Case (Guide DIVQ, File E129899) Complies with the requirements of the CSA Standard for Molded Case Circuit Breakers,

CANCSA- C22.2 No. 5.1 –M

Circuit Breakers for Use in Communications Equipment (Guide DITT, File E189195)

TUV Certified



IEC 60947-2

Low Voltage Switchgear and Control Gear under TUV License No. R72031058

UL 489A



Circuit & Terminal Diagrams: in. [mm]

F SERIES NON-PARALLEL POLE CONSTRUCTION:

CIRCUIT BREAKER PROFILE	CIRCUIT SCHEMATIC		CIRCUIT CODE	AUX. SWITCH CODE	CIRCUIT SCHEMATIC		CIRCUIT CODE	AUX. SWITCH CODE
	ANSI	IEC			ANSI	IEC		
<p>2.965 [75.31] 1.328 [33.73] 5.991 [152.17] LOAD</p> <p>SERIES TRIP (2 TERM.S.)</p>	<p>LINE LOAD</p>	<p>LINE (NETZ) LOAD (LAST)</p>	A	0	<p>LINE LOAD</p>	<p>LINE (NETZ) (3) LOAD (LAST)</p>	BC	0
<p>2.733 [69.41] .222 [5.63] 2.496 [63.39] 2.091 [53.11] LOAD</p> <p>SERIES TRIP W/AUX. SWITCH (5 TERM.S.)</p>	<p>LINE LOAD</p>	<p>LINE (NETZ) LOAD (LAST)</p>	A	2 3 4 5 9	<p>LINE LOAD</p>	<p>LINE (NETZ) (3) LOAD (LAST)</p>	BC	2 3 4 5 9

TERMINAL DETAILS BACK CONNECT

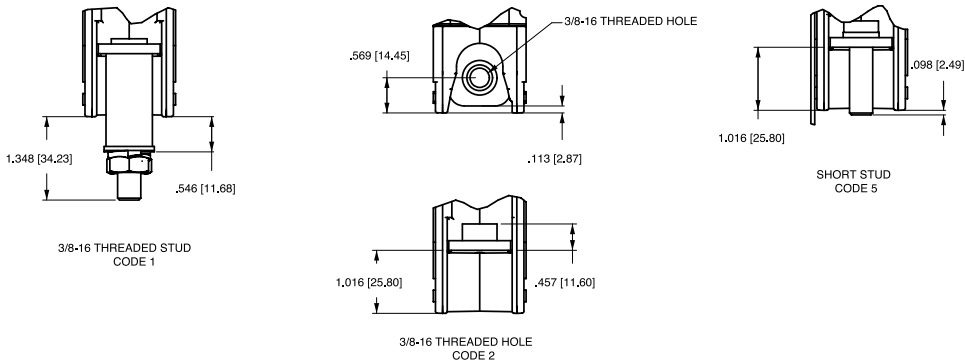

FRONT CONNECT

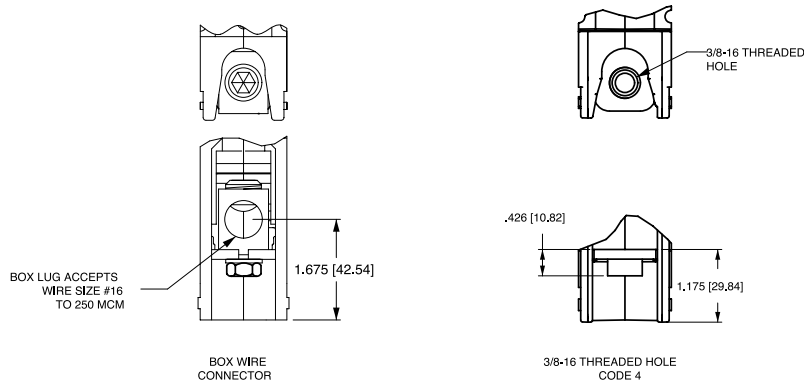

Notes:

- 1 All dimensions are in inches [millimeters].
- 2 Tolerance $\pm .020$ [.51] unless otherwise specified.

Circuit & Terminal Diagrams: in. [mm]

F-SERIES PARALLEL POLE CONSTRUCTION:

CIRCUIT BREAKER PROFILE	CIRCUIT SCHEMATIC		CIRCUIT CODE	AUX. SWITCH CODE	CIRCUIT SCHEMATIC		CIRCUIT CODE	AUX. SWITCH CODE
	ANSI	IEC			ANSI	IEC		
<p>SERIES TRIP (2 TERMS.)</p>	<p>SWITCH ONLY (NO COIL)</p>		A	0	<p>SERIES TRIP</p>		BC	0
<p>SERIES TRIP W/AUX. SWITCH (5 TERMS.)</p>	<p>SWITCH ONLY (NO COIL) WITH ALARM OR AUX. SWITCH</p>		A	B	<p>SERIES TRIP WITH ALARM OR AUX. SWITCH</p>		BC	B
<p>SERIES TRIP W/METERING SHUNT (4 TERMS.)</p> <p>(FOR 100-225 AMPS DIM = 2.000)</p>	<p>SWITCH ONLY (NO COIL) WITH METERING SHUNT</p>		N	0	<p>SERIES TRIP CURRENT COIL WITH METERING SHUNT</p>		M	0
<p>RELAY TRIP (4 TERMS.)</p>	<p>SWITCH ONLY WITH ALARM OR AUX. SWITCH AND METERING SHUNT</p>		N	A	<p>SERIES TRIP WITH ALARM OR AUX. SWITCH AND METERING SHUNT</p>		M	A

- Notes:
- 1 All dimensions are in inches [millimeters].
 - 2 Tolerance ± 0.020 [.51] unless otherwise specified.

Dimensional Specifications: in. [mm]

SERIES TRIP BACK CONNECT (STUD TERMINALS SHOWN)

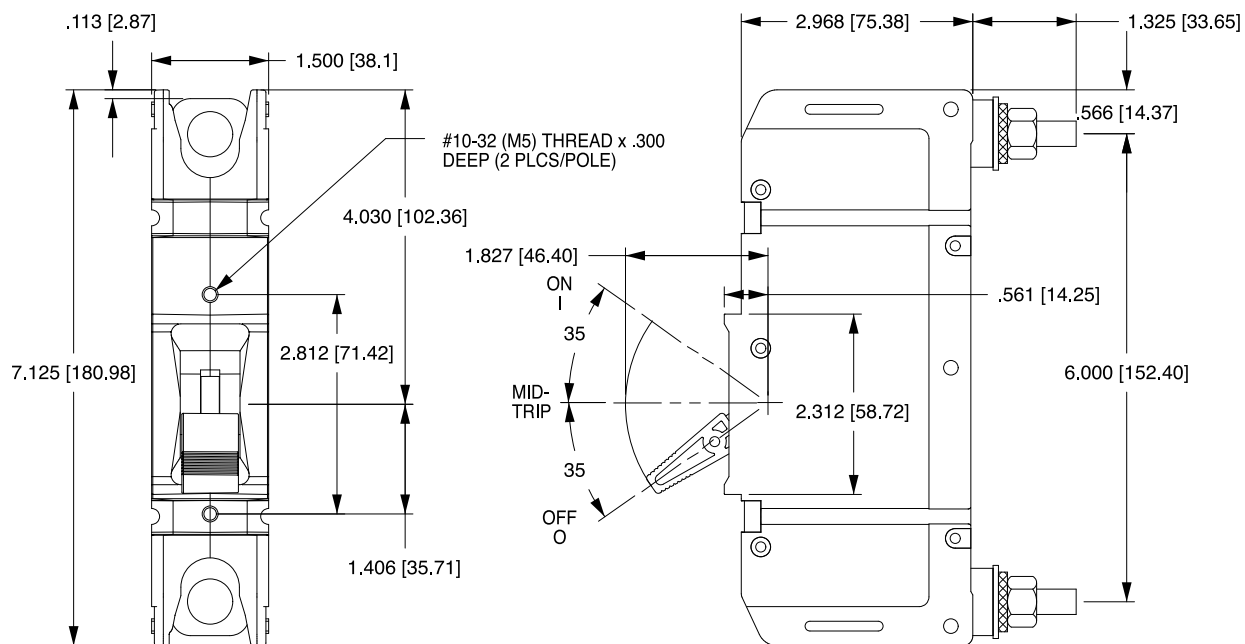

MULTIPOLE SERIES TRIP, SHOWING TERMINAL BARRIER

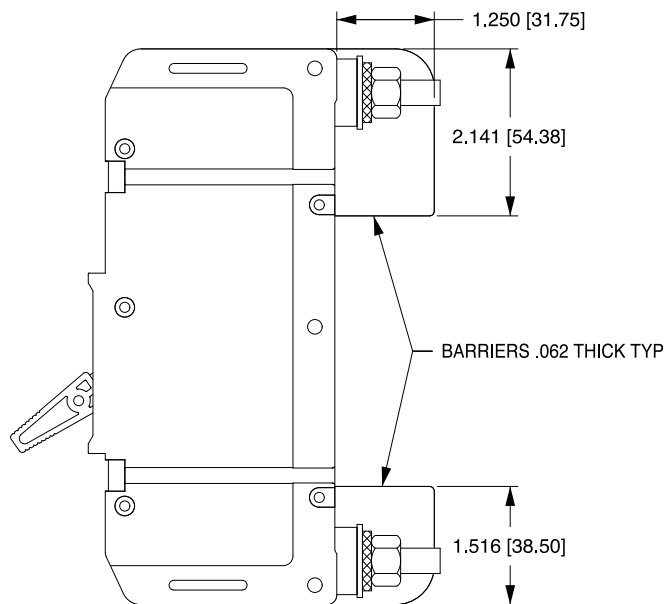
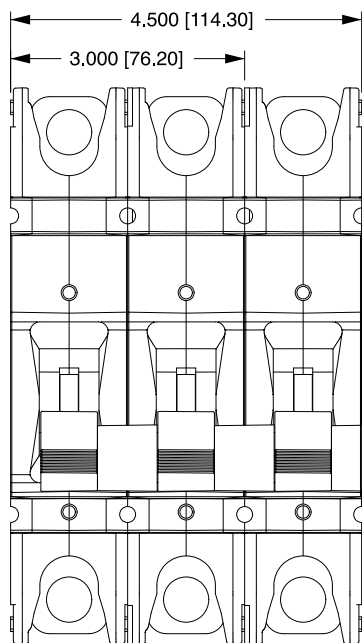

Notes:

- 1 All dimensions are in inches [millimeters].
- 2 Tolerance ± 0.020 [51] unless otherwise specified.

Dimensional Specifications: in. [mm]

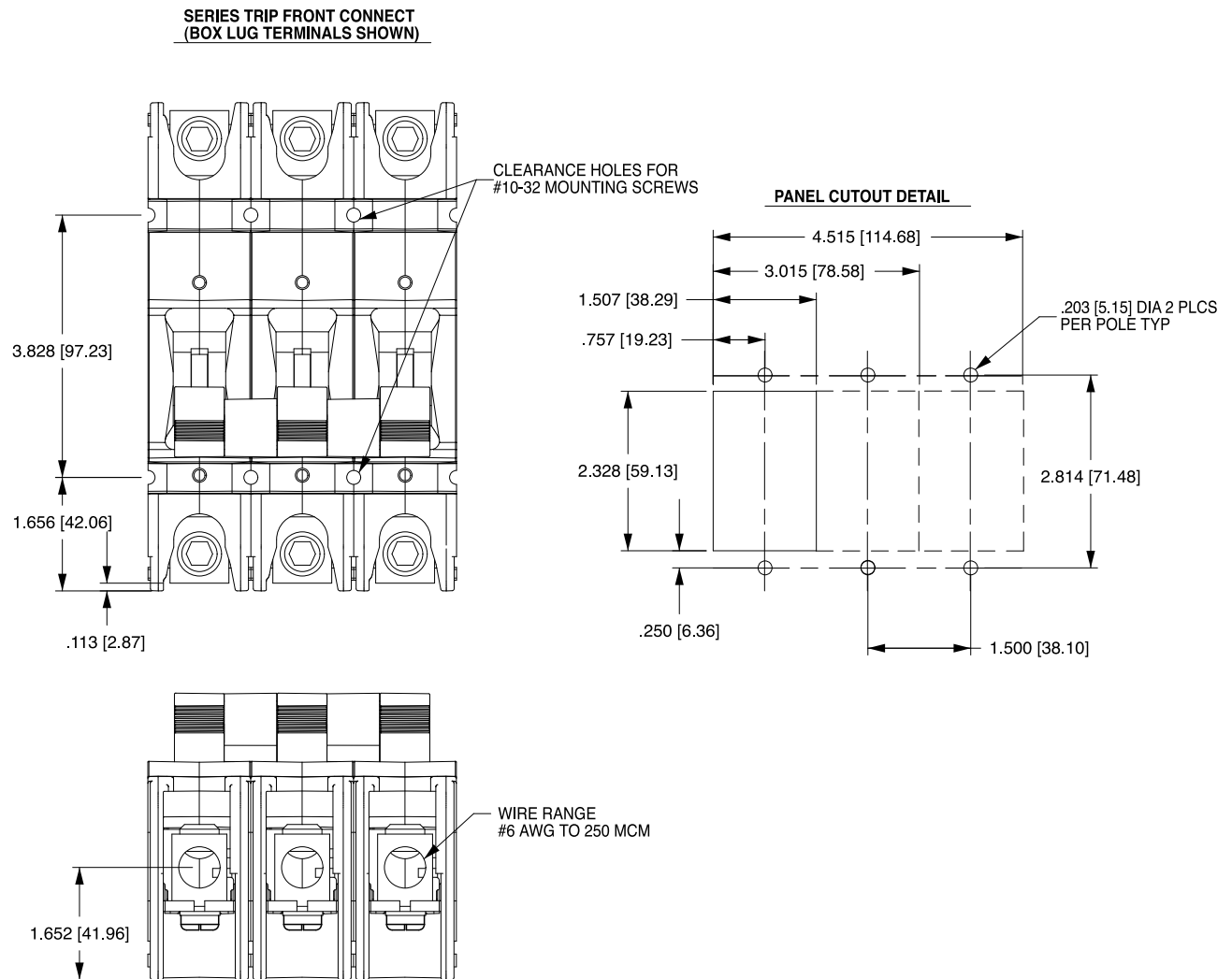

Notes:

- 1 All dimensions are in inches [millimeters].
- 2 Tolerance ± 0.020 [.51] unless otherwise specified.

Dimensional Specifications: in. [mm]

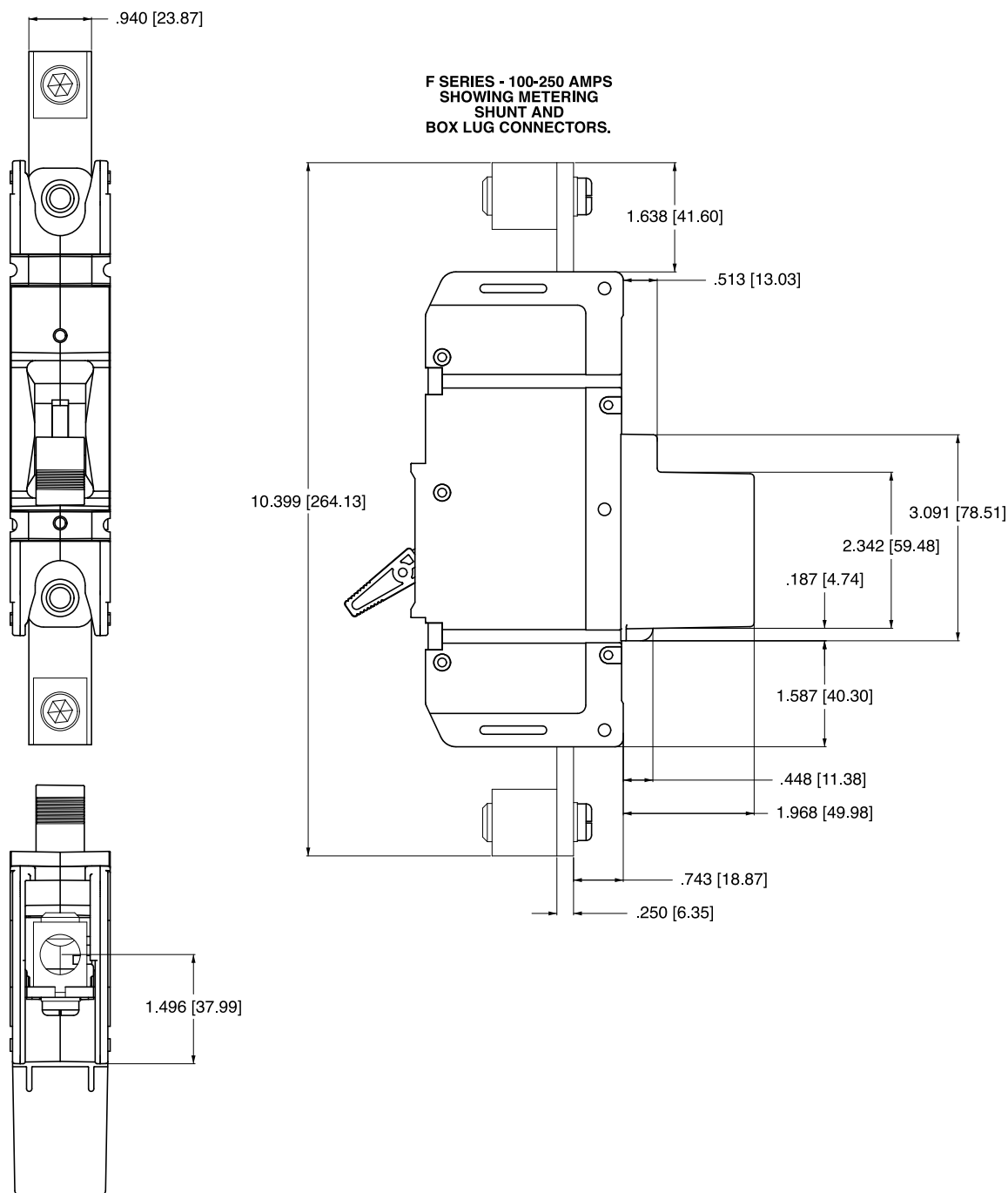

F-Series breakers are available up to 700A, and are also available with a 25 millivolt metering shunt construction. This optional construction provides a safe method for monitoring current flowing through the breaker by simply connecting a meter with light gauge wire to the appropriate terminals located on the shunt housing at the rear of the breaker. You can customize the application by measuring and displaying percentage of current, watts or safe/danger zones.

Notes:

- 1 All dimensions are in inches [millimeters].
- 2 Tolerance $\pm .020$ [.51] unless otherwise specified.

Dimensional Specifications: in. [mm]

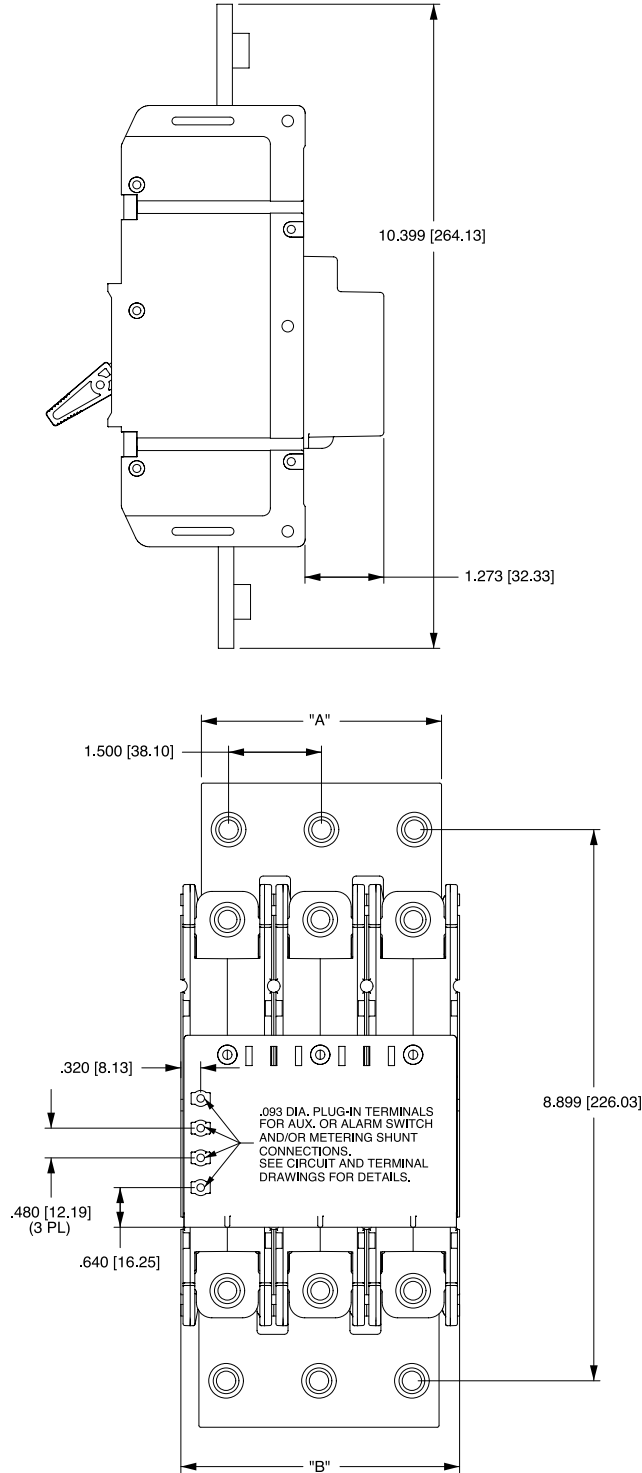

**F-SERIES PARALLEL POLE 250-700 AMPS
SHOWING FRONT CONNECT SCREW TERMINALS**

- Notes:
- 1 All dimensions are in inches [millimeters].
 - 2 Tolerance ± 0.020 [.51] unless otherwise specified.

F-SERIES TIME DELAY VALUES									
TRIP TIME SECONDS	Delay	PERCENT OF RATED CURRENT							
		100%	125%	150%	200%	400%	600%	800%	1000%
11	No Trip	.013 - .125	.010 - .070	.008 - .032	.006 - .020	.005 - .020	.004 - .020	.004 - .020	.004 - .020
12	No Trip	.475 - 10.0	.275 - 2.80	.140 - .850	.030 - .190	.015 - .125	.010 - .050	.008 - .038	.008 - .038
14	No Trip	10.0 - 110	6.00 - 40.0	2.50 - 15.0	.500 - 3.00	.180 - 1.00	.010 - .280	.008 - .080	.008 - .080
16	No Trip	110 - 1000	60.0 - 400	22.0 - 150	4.00 - 25.0	1.00 - 5.50	.010 - 1.80	.008 - .390	.008 - .390
22	No Trip	0.44 - 10.0	0.25 - 2.80	0.13 - 0.90	0.030 - 0.19	0.015 - 0.125	0.010 - 0.055	0.008 - 0.045	0.008 - 0.045
24	No Trip	7.20 - 110	4.40 - 45.0	2.00 - 18.0	0.25 - 3.50	0.016 - 1.60	0.009 - 0.33	0.008 - 0.11	0.008 - 0.11
26	No Trip	100 - 1100	32.0 - 400	14.0 - 150	2.50 - 25.0	0.020 - 11.0	0.010 - 3.10	0.008 - 0.39	0.008 - 0.39

